

# The Beiter PLUNGER

The Beiter Plunger, developed 1985 to 1986, was introduced at the Las Vegas Shoot 1987. Actually it is represented on archery fields world wide. At the Olympic Games in Atlanta 1996 about 80% of the archers were using the Beiter Plunger.

The Beiter Plunger is produced out of precision machined parts (the Beiter company supplies the watch-, precision-mechanic- and medical-industry and is used to work only with the finest materials). The notching scale cylinder allows an exact and reproducible spring tension time after time.

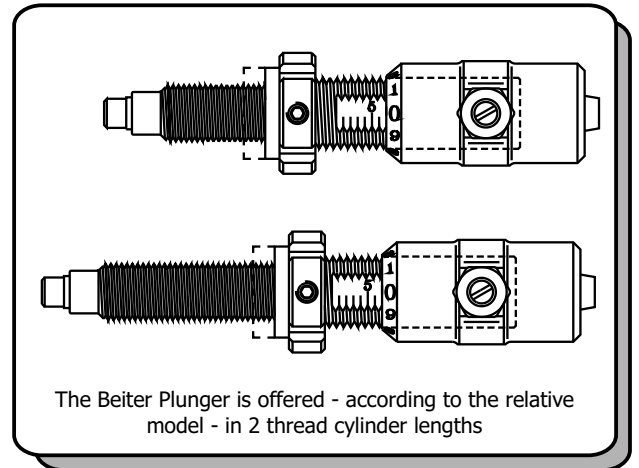

The thread cylinder is made out of high-grade refined steel, the springs out of stainless harmonic steel, the notching scale cylinder and the slotted nut out of anodised aluminum. The material used for the Plunger Pin offers excellent glide- and wear-behaviour by using aluminum-, aluminum-carbon- or carbon-arrows.

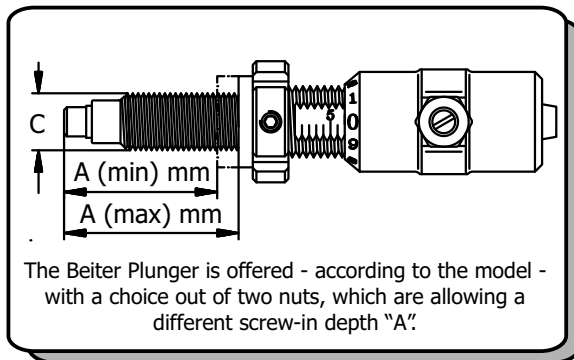

#### Sales Unit:

- ⇒ 1 Beiter Plunger with an installed hard spring (0.60)
- ⇒ 1 Open Spanner, 1 Spanner
- ⇒ 2 springs "extra hard" (0.70)
- ⇒ 1 spring "hard" (0.60)
- ⇒ 2 springs "soft" (0.45)
- ⇒ 1 Allen Head Wrench 1,5mm
- ⇒ 2 Allen Head Screws M3 for slotted nut
- ⇒ 2 screwgates M3 for Allen Head Screws
- ⇒ 6 Spare Pins

#### Colours:

Blue (BL), Darkblue (DB), Gold (GO), Red (RT), Black (SW), Silver (SI), Titan (TI)

#### Code-numbers:

The Code-number for the Beiter Plunger consists out of:

**Product Group (PL)/Model/Colour**, e.g.

- **PL 6523.0 GO** -> Plunger, 5/16"-24, Dist. "A" min.17.5-max.23.0mm, Colour Gold

<b>PLUNGER</b>			
<b>5/16"-24</b>			
<b>Code#</b>	<b>Screw Length</b>	<b>Pin</b>	<b>Nut</b>
<b>Thread Cylinder 53,5mm</b>			
PL6521.5__	17.5-21.5	6x34 mm	11 mm
PL6523.0__	17.5-23.0	3x34/3x36mm	11 mm
PL6524.5__	21.5-24.5	6x34 mm	7 mm
PL6526.5__	23.5-26.5	6x36 mm	7 mm
PL6527.0__	21.5-27.0	3x34/3x36mm	7 mm
<b>Thread Cylinder 61,5mm</b>			
PL6529.5__	25.5-29.5	6x42 mm	11 mm
PL6532.5__	29.5-32.5	6x42 mm	7 mm
PL6534.5__	31.5-34.5	6x44 mm	7 mm
<b>M8x0,75</b>			
<b>Thread Cylinder 61,5mm</b>			
PL6829.5__	25.5-29.5	6x42 mm	11 mm
PL6832.5__	29.5-32.5	6x42 mm	7 mm
PL6834.5__	31.5-34.5	6x44 mm	7 mm

# The Beiter PLUNGER

## Eigenschaften:

Each single Plunger has a 3 to 4mm variable screw length "A".

By changing single parts of it - Pin and/or slotted nut and/or thread cylinder - a screw-in length from 17.5 mm up to 34.5 mm can be reached.

The available combinations are shown on the table on the previous page.

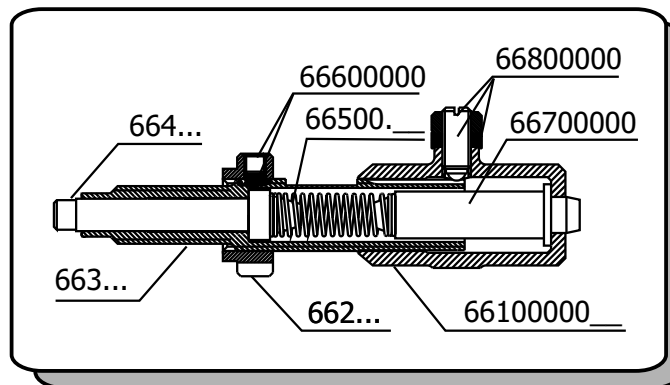
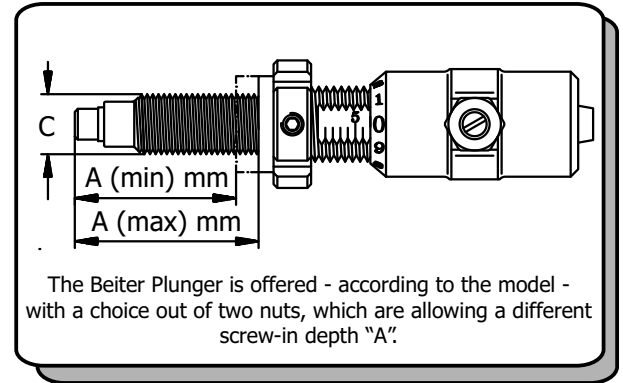

## PLUNGER SPARE PARTS

Code#	Description	Colours
PL66100000__	Notching Scale Cylinder	<b>SW</b> =Black, <b>SI</b> lver, <b>BL</b> ue, <b>RT</b> =Red, <b>GO</b> ld, <b>DA</b> rk <b>BL</b> ue, <b>TI</b> tan
PL66200007__	Slotted Nut, Length 7 mm	<b>SW</b> =Black, <b>SI</b> lver, <b>BL</b> ue, <b>RT</b> =Red, <b>GO</b> ld, <b>DA</b> rk <b>BL</b> ue, <b>TI</b> tan
PL66200011__	Slotted Nut, Length 11 mm	<b>SW</b> =Black, <b>SI</b> lver, <b>BL</b> ue, <b>RT</b> =Red, <b>GO</b> ld, <b>DA</b> rk <b>BL</b> ue, <b>TI</b> tan
PL663553.5	Thread Cylinder 5/16-24, Short, 53.5 mm	
PL663561.5	Thread Cylinder 5/16-24, Long, 61.5 mm	
PL663861.5	Thread Cylinder M8x0.75, Long, 61.5 mm	
PL663153.5	Thread Cylinder M10x1, Short, 53.5 mm	
PL66400034	Pin, Light, Length 34 mm	
PL66400036	Pin, Black, Length 36 mm	
PL66400042	Pin, Green, Length 42 mm	
PL66400044	Pin, Darkgreen, Length 44 mm	
PL66500.45	Spring "soft" (0.45)	
PL66500.60	Spring "hard" (0.60)	
PL66500.70	Spring "extra hard" (0.70)	
PL66600000	Distance-bolt for spring	
PL66700000	Allen head screw and washer	
PL66800000	Spring Ball Complete	
PL66900001	Spanner for Plunger, yellow	
PL66900011	Open Spanner for Plunger, red	
PL66900002	Allen head wrench 1.5 mm	

# The Beiter PLUNGER

## HINTS AND MAIN FEATURES:

- ⇒ The Beiter Plunger has a "hard" spring mounted (0.60 mm thickness).
- ⇒ If during the tuning of your bow the notching scale cylinder goes close to 0 on the thread scale, change to the "extra hard" spring (0.70 mm thickness). This usually occurs if the arrow reacts too weak.
- ⇒ If the thread scale goes close to 10, then replace the "hard" spring with the "soft" spring (0.45mm thickness). This usually occurs if the arrow reacts too stiff.
- ⇒ Following table - included in each sold Plunger - shows how the single springs are reacting: with the "hard" spring (0.60) on scale position 1.0 you will reach a tensile strength of approx. 8N (Newton). You can reach the same tensile strength with an "extra hard" spring (0.70) on scale position 7.5.
- ⇒ **Important:** A wrong arrow (an arrow with the wrong spine) cannot be compensated by any plunger!

